

OPERATION MANUAL

DVFR-4 Filter Regulator

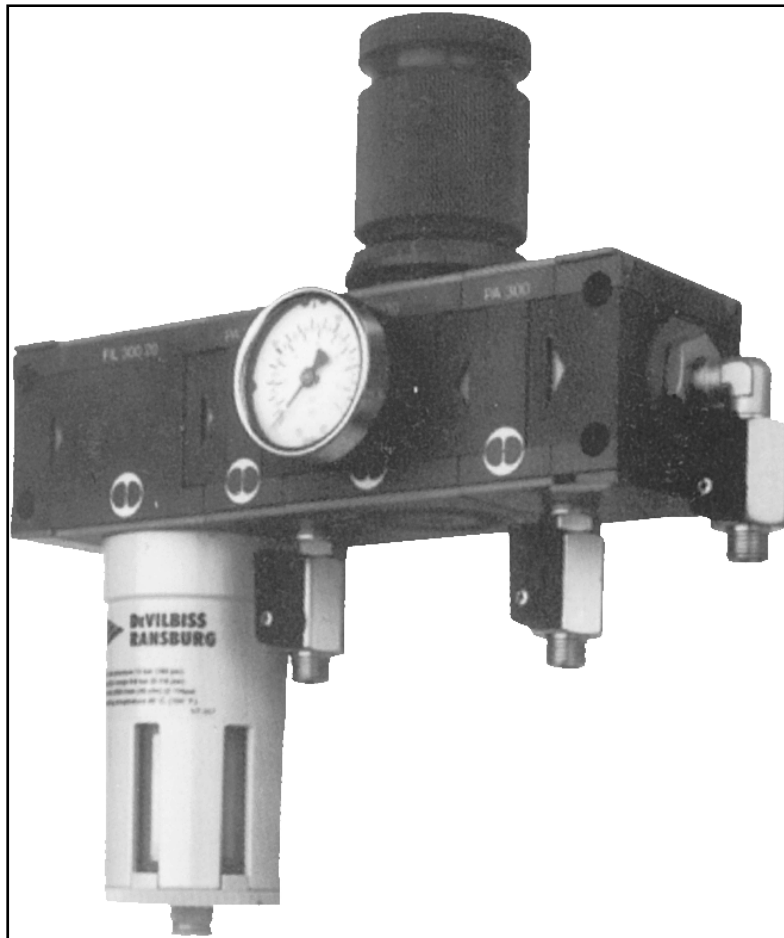

E	P 2-3	D	P 4-5
F	P 6-7		



Operation Manual

DVFR-4 Filter Regulator

Important

Read and follow all instructions and Safety Precautions before using this equipment

Description

A compressed air Filter Regulator with two regulated outlets and one unregulated outlet. The 5 micron filter removes entrained dirt and liquid oil and water from the compressed air supply for regulated and unregulated outlets. A semiautomatic drain is fitted to the condensate bowl that drains collected liquid when the air supply is turned off and pressure released.

Regulator is a self relieving design that senses over-pressure at the regulated outlets and vents excess pressure to atmosphere. The rolling diaphragm improves pressure sensitivity adjusting the valve for fluctuating airflows and pressures.

Model

Order No. DVFR-4 Filter regulator unit. Complete with air pressure gauge and mounting bracket.

Air supply connection 1/2" BSP female.
 Air outlet connections 1/4" BSP male.
 Gauge port 1/8" BSP female.
 Size width 105 mm
 height 280 mm
 length 290 mm

Weight 2.95 Kg
 Maximum:
 air flow 2550 l/min
 air supply pressure 13 bar
 regulated air pressure 8 bar
 operating temperature 40° C

Filter aperture size 5 micron
 Typical pressure drop 0.75 bar

Parts List

Ref No	Part No	Description
1	DV-9450806	Upper Cover Assembly including diaphragm
2	DV-9351705	Replacement Filter Element (20 microns)
3	DV-9453301	Filter Bowl with drain valve
4	SER-3414-MF	Ball Valve 1/4 inch BSP (m) & (F)
5	GA-319	Pressure Gauge 0-160 psi

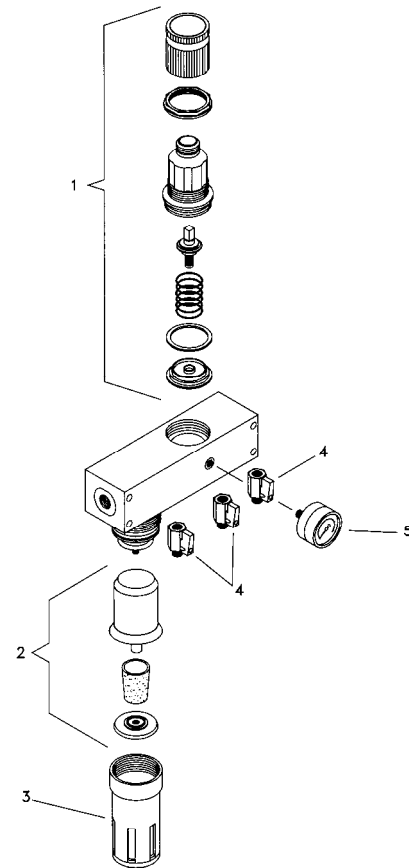



SAFETY WARNINGS



Misuse

- Never exceed the recommended safe working pressure/temperature for any of the equipment used.
- Do not use paint solvents to clean the unit or filter element.
- The fitting of non- recommended or non- original accessories or spare parts may create hazardous conditions.
- Do not install the unit above electrical or any other equipment that will be damaged by discharged condensate.
- Before dismantling the equipment for cleaning or maintenance, all air pressures must be isolated and released.
- When assembling an air pressure gauge to the unit DO NOT use a spanner, always tighten by hand.
- The disposal of non-metallic materials must be carried out in an approved manner. Burning may generate toxic fumes.

Installation

1. Install the unit as near as possible to the point of use.
2. An isolation valve should be fitted close to the inlet of the unit to allow condensate to be drained and for ease of maintenance.
3. Connect the air supply to the unit so that the air flows in the direction indicated by the arrows on the body.
4. The unit can be mounted on ridged pipe work, with wall bracket supplied or panel mounted. To bracket/ panel mount, pull regulator knob off and secure to bracket/panel with the 48 x 1.5 mm lock-nut ,or fix to panel with (4) 5 mm screws.
5. Ensure the earth lead is connected to an earth point and verify continuity from each ball valve (item 4) to another known earth point, a resistance of less than 1k ohm should be achieved for dissipation of electrostatic charge.

Operation

Regulator

Turn knob counter-clockwise fully, then adjust to the pressure required by turning knob clockwise until the desired pressure is indicated on the gauge. When reducing the pressure, always reduce below the required pressure and adjust upwards.

Note: The adjusting knob has a locking feature, press down to lock, lift to unlock.

Filter drain valve

The condensate drain valve at the bottom of the filter can be used semi-automatically or manually. The level of condensate can be seen through the vision slots.

For semi-automatic operation : Turn valve knob counter-clockwise. Turn off supply air and open regulated valve to release pressure. If necessary it is possible to drain condensate when the bowl is pressurised by manually pushing the valve up.

Note: The drain valve can be locked to prevent condensate draining by turning the valve clockwise.

Maintenance

Cleaning: The filter element can be removed and cleaned, by removing condensate bowl and unscrewing tie rod.

Note: To unscrew the bowl from the unit, use a compass key (pin spanner) with 3mm diameter pins

It is recommended that filter/coalescer/activated carbon elements are replaced periodically i.e. when a drop in pressure is noticeable through the unit or every 6 months.

Ensure earthing of the unit is not affected by maintenance activities , see installation above.

ITW Finishing Systems and Products
Ringwood Road,
Bournemouth,
BH11 9LH,
England.
Tel. No. (01202) 571111
Telefax No. (01202) 581940,
Website address <http://www.itweuropeanfinishing.com>

ITW Oberflächentechnik GmbH & Co. KG
Justus-von-Liebig-Straße 31
63128 Dietzenbach
Tel (060 74) 403-1
Telefax: (060 74) 403300
Website address <http://www.itw-finishing.de>

ITW Surfaces Et Finitions
163-171 avenue des Auréats B.P. 1453
26014 VALENCE CEDEX FRANCE
Tél. (33) 475-75-27-00
Télex 345 719F DVILBIS
Téléfax: (33) 475-75-27-99

ITW Finishing Systems and Products is a Division of ITW Ltd.
Reg. Office:
Admiral House,
St Leonard's Road,
Windsor,
Berkshire,
SL4 3BL,
UK
Registered in England: No 559693 Vat No 619 5461 24