

DEVILBISS

EN



SB-E-2-845 ISS.01

CE Ex II 2 G X

Technical Bulletin

GTIPRO LITE HVLP and High Efficiency Suction and Pressure Spray Guns



Table of Contents

Topic	Page
EC Declaration of Conformity	3
Part Numbers	3
Operational Description	3
Kit contents	4
Construction Features	4
Materials of Construction	4
Specifications & Technical Data	4
Safety Precautions	5
Parts List	6
Exploded parts View	7
Installation, Operation, Preventive Maintenance & Cleaning	8
Parts Replacement/Maintenance	9
A. Servicing Air Valve	9
B. Needle Packing, Fluid Inlet Seal, Spreader Valve Assembly	11
C. Spray Head Seal Replacement	12
D. Suction Cup Lid Maintenance	13
E. Chart 1 – Air Caps, Chart 2 – Fluid Nozzles & Fluid Needles	13
Troubleshooting Possible Problems in Operation	14
Accessories	16
Warranty	16

EC Declaration of Conformity

We, ITW Finishing UK, Ringwood Rd, Bournemouth, Dorset, BH11 9LH, UK, as the manufacturer of the Spray gun model **GTIPRO LITE**, declare, under our sole responsibility that the equipment to which this document relates is in conformity with the following standards or other normative documents:

BS EN 12100 PARTS 1 & 2: 2010, BS EN 1953: 1998+A1:2009; and thereby conform to the protection requirements of Council Directive 98/37/EEC relating to Machinery Safety Directive, and;

EN 13463-1:2009, council Directive 94/9/EC relating to Equipment and Protective Systems intended for use in Potentially Explosive Atmospheres protection level II 2 G X.

This product also complies with the requirements of the EPA guidelines, PG6/34. Transfer efficiency certificates are available on request.



D Smith, General Manager
2nd February 2012

ITW Finishing Systems and Products reserve the right to modify equipment specification without prior notice.

Part Numbers

The ordering code for the **GTIPRO LITE** Spray gun is;

E.g. **PROPL-TE30-12** where;

P	=	Pressure or S for Suction
TE30	=	TE30 Air cap
12	=	1.2mm Nozzle

See charts 1 & 2 p13 for available Air cap / Nozzle sizes

Operational Description

This **GTIPRO LITE** Spray Gun is a professional quality gun designed with both high volume, low pressure (HVLP) technology or High Efficiency EPA compliant technology. HVLP Technology reduces overspray and limits air cap pressure to 0.7 bar (10 psi). High Efficiency complies with EPA by obtaining transfer efficiency above 65%.

IMPORTANT: These Spray guns are suitable for use with both water-based and solvent-based coating materials. These guns are not designed for use with highly corrosive and/or abrasive materials and if used with such materials it must be expected that the need for cleaning and/or replacement of parts will be increased. If there is any doubt regarding the suitability of a specific material, contact your DeVilbiss Distributor or DeVilbiss direct.

NOTE: This gun is not to be used with halogenated hydrocarbon solvents or cleaning agents such as 1,1,1,-Trichloroethane or methylene chloride. These solvents can react with the aluminium components used in this gun and cup. The reaction can become violent and lead to an equipment explosion.

Kit contents (all models)			
1	GTIPRO LITE Suction or Pressure Feed Spray gun	1	Spanner (10mm and 14mm A/F)
1	KR 1 litre Suction feed Cup (Suction models only)	1	Torx / Flat blade screwdriver
1	Cup Filter (Suction models only)	1	Cleaning Brush
1	Set of 4 coloured identification rings	1	Service bulletin

Construction Features			
1	Air Cap (nickel plated brass for long durability)	10	Fan Air Adjustment (step-less regulation for fan to round spray)
2	Air Cap Retaining Ring (allows easy rotation of air cap)	11	Fluid Adjustment (step-less regulation of fluid volume)
3	Fluid Nozzle (ideal for most paint systems)	12	Interchangeable Colour ID System (4 coloured rings supplied)
4	Fluid Needle (grooved stem for easy removal)	13	Anodised, forged aluminium gun body (ergonomic, good looking & durable, easy to clean)
5	Fluid Inlet (Universal 3/8" (BSP & NPS) thread – accepts DeVilbiss and most other cup systems)	14	1 litre Aluminium Suction Cup (Suction models only)
6	Air Inlet (Universal 1/4 " thread, accepts BSP & NPS)	15	Cup Lid with Drip Free Vent (avoid drips)
7	Self -Adjusting Needle Packing (for trouble free operation)	16	Air Valve (design offers low pull force & low pressure drop)
8	Trigger (ergonomic for comfort)	17	Gun acceptable for waterborne and solvent borne applications
9	Trigger Stud & Screw (easy replacement design)		

Materials of Construction	
Gun Body	Anodised aluminium
Air Cap,	Nickel plated brass
Fluid Nozzle, Fluid Needle, Fluid Inlet, Trigger Stud	Stainless steel
Adjusting Knobs	Anodized aluminium
Springs, Clips, Screws	Stainless steel
Seals, Gaskets	Solvent resistant
Trigger	Chrome plated steel
Air Inlet, Body Bushing, Spreader & Cheater Valve Bodies, Air Valve Nut, Air Cap Retaining Ring, & air valve housing	Chrome plated brass
Air Valve Spindle	Nickel plated brass

Specifications & Technical Data	
Air Supply Connection	Universal 1/4" BSP and 1/4" NPS male
Maximum Static Air Inlet Pressure	P1 = 12 bar (175 psi)
Maximum Static Fluid inlet Pressure	P2 = 15 bar (217 psi)
Gun Air Inlet Pressure for HVLP and High Efficiency [®] both with gun triggered.	1.75 bar (25.4 psi) 2.00 bar (29.0 psi)
Fluid Supply Connection	3/8" BSP
Service Temperature	0 to 40°C (32 to 104°F)
Gun Weight (gun only) (with cup)	500g 935g



SAFETY WARNINGS

Fire and explosion



Solvents and coating materials can be highly flammable or combustible when sprayed. ALWAYS refer to the coating material supplier's instructions and COSHH sheets before using this equipment.



Users must comply with all local and national codes of practice and insurance company requirements governing ventilation, fire precautions, operation and house-keeping of working areas.



This equipment, as supplied, is NOT suitable for use with Halogenated Hydrocarbons.



Static electricity can be generated by fluid and/or air passing through hoses, by the spraying process and by cleaning non-conductive parts with cloths. To prevent ignition sources from static discharges, earth continuity must be maintained to the spray gun and other metallic equipment used. It is essential to use conductive air and/or fluid hoses.



Personal Protective Equipment



Toxic vapours – When sprayed, certain materials may be poisonous, create irritation or be otherwise harmful to health. Always read all labels, safety data sheets and follow any recommendations for the material before spraying. If in doubt, contact your material supplier.



The use of respiratory protective equipment is recommended at all times. The type of equipment must be compatible with the material being sprayed.



Always wear eye protection when spraying or cleaning the spray gun.



Gloves must be worn when spraying or cleaning the equipment.

Training – Personnel should be given adequate training in the safe use of spraying equipment.

Misuse

Never aim a spray gun at any part of the body.

Never exceed the maximum recommended safe working pressure for the equipment.

The fitting of non-recommended or non-original spares may create hazards.

Before cleaning or maintenance, all pressure must be isolated and relieved from the equipment.

The product should be cleaned using a gun-washing machine, and should be removed and dried immediately after cleaning is completed. Prolonged exposure to cleaning solutions can cause damage to the product.

Noise Levels



The A-weighted sound level of spray guns may exceed 85 dB (A) depending on the set-up being used. Details of actual noise levels are available on request. It is recommended that ear protection is worn at all times when spraying.

Operating

Spray equipment using high pressures may be subject to recoil forces. Under certain circumstances, such forces could result in repetitive strain injury to the operator.

PARTS LIST

REF. NO.	DESCRIPTION	PART NO.	QTY	REF. NO.	DESCRIPTION	PART NO.	QTY
1	Air Cap Retaining Ring	-	1	33	Air Inlet Kit	SN-9-K	1
2	Slip Ring	-	1	34	Needle Packing	-	1
3	Air Cap	-	1	35	Packing Spring	-	1
4	Air Cap Retaining Clip	JGA-156-K5	1	36	Packing Nut	-	1
5	Retaining Ring Seal	-	1	*37	Packing, Spring and Packing Nut Kit	SN-404-K	1
6	Aircap & Ring	See chart 1 p13	1	*38	Trigger Screw	-	1
7	Air Cap Retaining Ring & Seals	PRO-420-K	1	39	Trigger	-	1
8	Fluid Nozzle Kit	See chart 2 p13	1	*40	Trigger Stud	-	1
9	Spray Head	-	1	41	Trigger Stud & Screw Kit	SP-617-CR-K	1
*10	Spray head Seal	SN-18-1-K2	1	42	Airflow Valve	PRO-407-K	1
11	Spray head kit	SN-69-K	1	43	Circlip - Kit of 5	25746-007-K5	1
*12	Circlip	-	1	44	Valve Head	-	1
13	Valve Body	-	1	45	Washer	-	1
*14	O Ring	-	1	46	Valve Body	-	1
*15	Spreader Valve Pin	-	2	47	Valve Adjusting Knob	-	1
16	Spreader Valve Adjusting Knob	-	1	48	Seal	SP-636-K	1
17	Spreader Valve Assembly	PRO-408-K	1	49	Lock nut	-	1
18	Front Valve Seal	-	1	50	Fluid Inlet	-	1
19	Valve Seat	-	1	51	Fluid inlet Kit	ADV-7-K	1
20	Spindle	-	1	Suction Cup Models only			
21	Air Valve Spring	-	1	52	Suction Cup Kit	KR-566-1-B	1
22	Rear Valve Seal	-	1	53	Cup Lid Gasket – Kit of 3	KR-11-K3	1
23	Air Valve Kit	PRO-471	1	54	Drip Check Diaphragm (kit of 5)	KR-115-K5	1
24	Fluid Needle	See chart 2 p13	1	55	Filter – Kit of 10	KR-484-K10	1
25	Needle Spring	-	1	56	Lid Assembly	KR-4001-B	1
26	Spring Pad	-	1	57	Cup	KR-466-K	1
27	Housing	SN-66-K	1	+58	Air Valve Service Tool	-	1
28	Fluid Adjusting Knob	SN-67-C-K	1	59	Tool Kit	SN-406	1
*29	Needle Spring Kit	PRO-472-K3	1	SERVICE PARTS			
30	Gun Body	-	1	Spray Gun repair kit (includes items marked *)		PRO-470	
31	Air Inlet	-	1	Seal and Pin Kit, kit of 5 (items 12, 14 and 15)		GTI-428-K5	
32	Colour ID Ring Kit (4 colours)	SN-26-K4	1	+ Not included in the Gun Kit, only with ref 23			

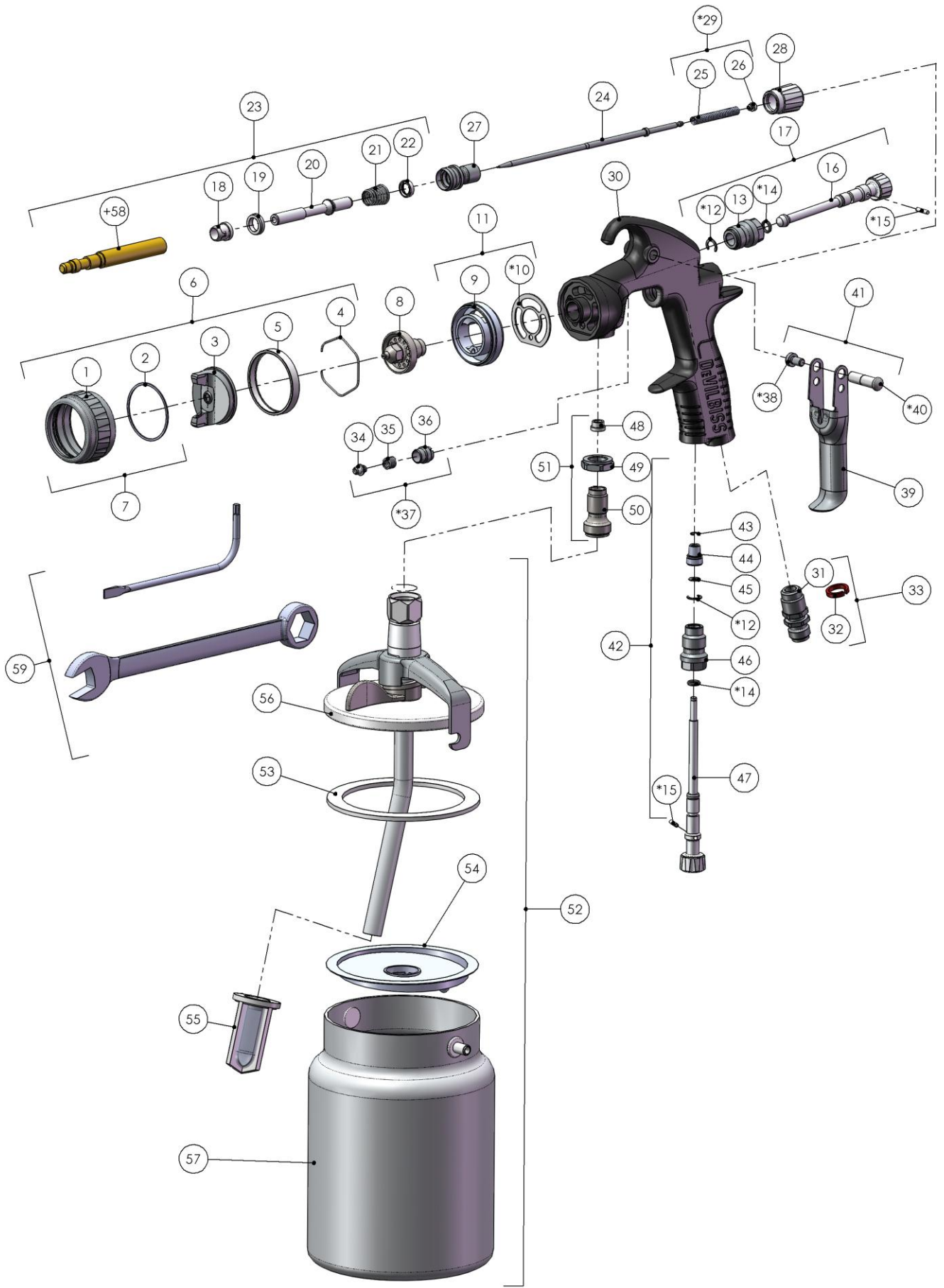

INSTALLATION

For maximum transfer efficiency, do not use more pressure than is necessary to atomise the material being applied. **NOTE: when using HVLP do not exceed 1.75 bar inlet pressure.**

1. Connect the gun to a clean, moisture and oil free air supply using a conductive hose of at least 8 mm I.D.

NOTE

Depending on hose length, larger I.D. hose may be required. Install an air gauge at the gun handle. When gun is triggered on, adjust regulated pressure to 2.0 bar for High Efficiency Air caps and 1.75 bar for HVLP. Do not use more pressure than is necessary to atomise the material being applied. Excess pressure will create additional overspray and reduce transfer efficiency.

NOTE

If quick connect couplings are required, use only high flow quick connects approved for HVLP use. Other types will not flow enough air for correct gun operation.

NOTE

If an air adjusting valve is used at the gun inlet, use DGIPRO-502-BAR Digital Gauge. Some competitive adjusting valves have significant pressure drop that can adversely affect spray performance. The DGIPRO Digital Gauge has minimal pressure drop, which is important for HVLP spraying.

2. **SUCTION MODELS ONLY.** Attach the cup lid assembly (52) to the fluid inlet connector (50). Position the yoke at right angles to the gun with the cam lever to the front (see picture). Make sure the vent hole in drip free diaphragm (54) is 180° to the lid vent hole.
3. **PRESSURE FEED MODELS.** Connect the fluid supply hose to Fluid inlet Connector (50).

NOTE

Before using the spray gun, flush it with solvent to ensure that the fluid passages are clean.

OPERATION (SUCTION MODELS)

1. Mix coating material to manufacturer's instructions and strain material.
2. Fill the cup to no more than 20 mm from the top of the cup. **DO NOT OVERFILL.**
3. Attach to Cup Lid.

ALL MODELS

4. Turn fluid adjusting knob (28) clockwise to prevent fluid needle movement.

5. Turn spreader valve adjusting knob (16) counter clockwise to fully open.
6. Adjust inlet air pressure if required.
7. Turn fluid adjusting knob counter clockwise until first thread shows.
8. Test spray. If the finish is too dry, reduce airflow by reducing air inlet pressure.
9. If finish is too wet, reduce fluid flow by turning fluid adjusting knob (28) clockwise. If atomisation is too coarse, increase inlet air pressure. If too fine, reduce inlet pressure.
10. The pattern size can be reduced by turning spreader valve knob (16) clockwise.
11. Hold gun perpendicular to surface being sprayed. Arcing or tilting may result in uneven coating.
12. The recommended spray distance is 150-200 mm.
13. Spray edges first. Overlap each stroke a minimum of 75%. Move gun at a constant speed.
14. Always turn off air supply and relieve pressure when gun is not in use.

PREVENTIVE MAINTENANCE & CLEANING

To clean air cap and fluid nozzle, brush exterior with a stiff bristle brush. If necessary to clean cap holes, use a broom straw or toothpick if possible. If a wire or hard instrument is used, extreme care must be used to prevent scratching or burring of the holes which will cause a distorted spray pattern.

To clean fluid passages, remove excess material from cup, then flush with gun wash solution. Wipe the gun exterior with a dampened cloth. Never completely immerse in any solvent or cleaning solutions as this is detrimental to the lubricants and life of the spray gun.

NOTE

When replacing the fluid nozzle or fluid needle, replace both at the same time. Using worn parts can cause fluid leakage. See page 13, Chart 2. Also, replace the needle packing at this time. Torque the fluid nozzle to 18–20 Nm. Do not over tighten.

CAUTION

To prevent damage to fluid nozzle (8) or fluid needle (24), be sure to either 1) pull the trigger and hold while tightening or loosening the fluid nozzle, or 2) remove fluid adjusting knob (28) to relieve spring pressure against needle collar.

SUCTION CUP. Empty excess material and clean the cup. Make sure the vent holes in the Diaphragm (54) and the lid (56) are clear.

Parts Replacement/Maintenance

AIR VALVE INSTRUCTIONS

Servicing Air Valve

Reasons to service air valve:

- A) Air valve not functioning correctly (may need cleaning).
 - B) Routine maintenance.
 - C) Air leaks.
1. Remove trigger screw (38) with Torx tool (59) or Torx T20 key. (See fig 2).
 2. Remove trigger stud (40) and remove trigger (39). (See fig 3).
 3. Remove fluid adjusting knob (28) and spring (29). (See fig 4).
 4. Remove fluid needle (24). (See fig 5).
 5. Using a 6mm hex key, remove Valve housing (27). (See Figs 6 and 7).
 6. Remove spring (21) and valve spindle (20). (See Fig 8).
 7. Using service tool (58), engage groove behind the valve seat (19). (See Fig 9).
 8. Withdraw the valve seat (19) from the gun body. (See fig 10).
 9. Push out the front air-valve seal (18) with a finger. (See fig 11).
 10. Turn the Gun upside down and let the seal fall out. (See fig 12).
 11. Fit New front seal (18) to service tool (58). Fit into gun body and press firmly to ensure Seal is engaged. (See fig 13).

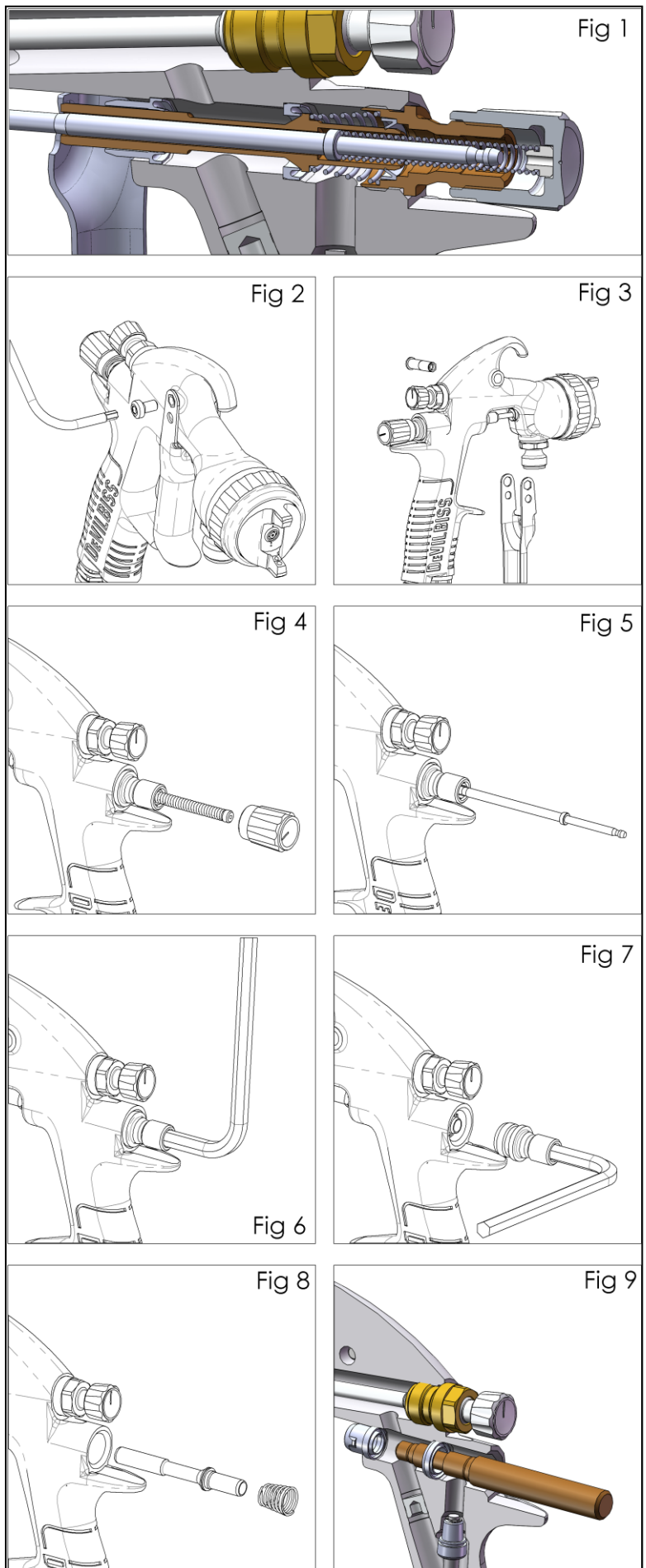

12. Fit a new valve seat (19) to service tool (58). Groove must face outwards. (See fig 14).
13. Fit valve seat (19) to gun-body. (See fig 15)
14. Remove rear air-valve seal (22) from housing (27) with a hooked instrument. (See fig 16).
15. Fit new seal (22) to service tool (58). Groove must face outwards. Press seal (22) to housing (27). (See fig 17)
16. Reassemble remaining parts in reverse order - valve spindle (20), spring (21), housing (27) and tighten with 6mm hex key, needle (24) spring (29) and knob (28). Replace trigger (39), fitting trigger stud (40) and screw in the trigger screw (38) with Key (59) or Torx Key T20.
17. Trigger gun fully and screw in fluid adjusting knob (28) until it stops. Back it off 1/2 turn and gun will have full needle travel.
18. Trigger gun several times to verify correct operation.

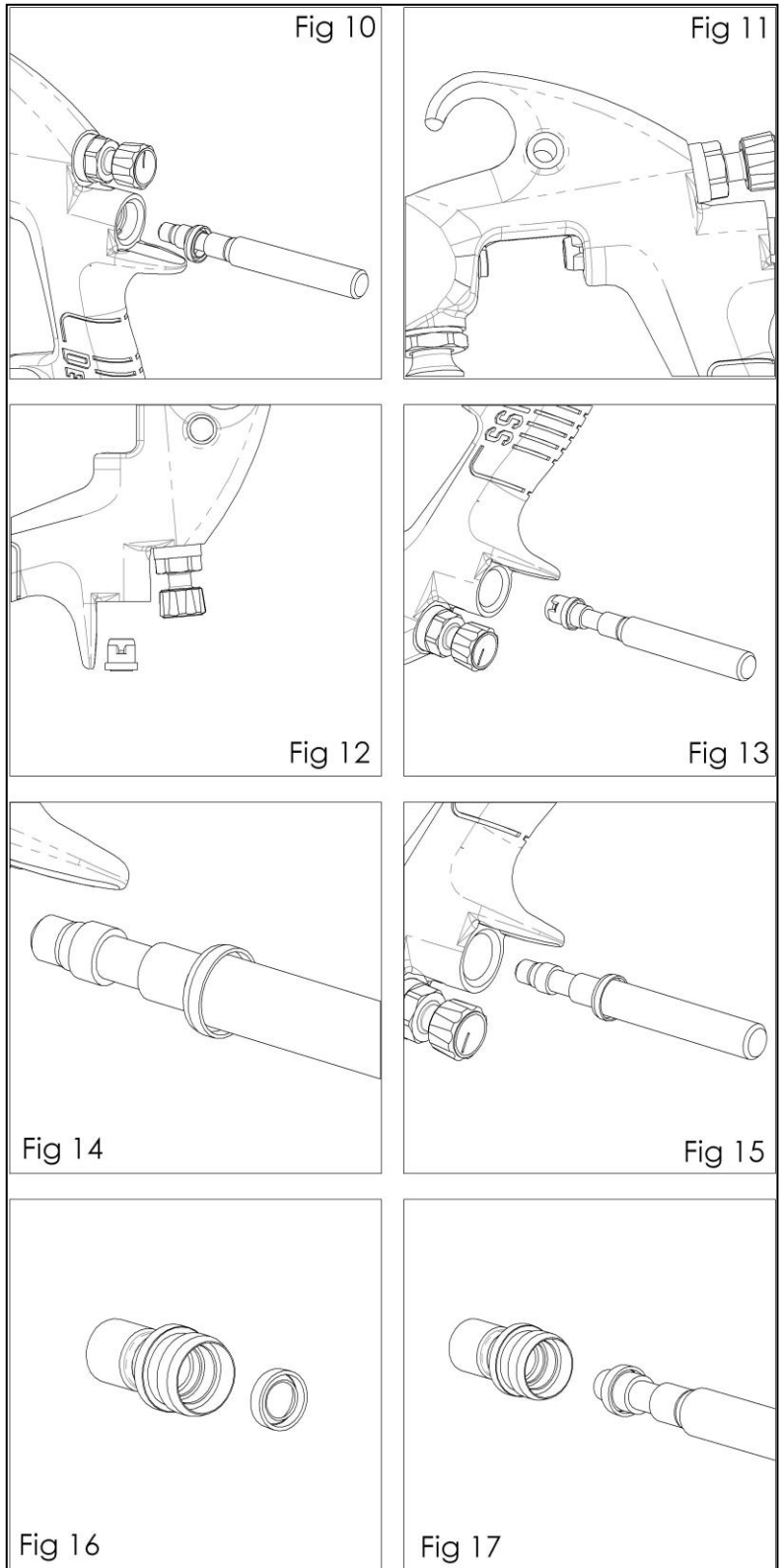

NEEDLE PACKING

REPLACEMENT INSTRUCTIONS

1. Remove trigger and needle following steps 1 to 6 on P9, servicing air-valve.
2. Loosen and remove packing nut using Key (part of 59) or a straight blade screwdriver. (See figs 18 & 19)
3. Discard old packing (34) and packing spring (35) if replacing. Clean packing if reusing. Also clean packing spring and nut (36). (See fig 20).
4. Re-assemble the packing, assemble into gun-body by hand and then tighten. (See fig 21)
5. Complete re-assembly.

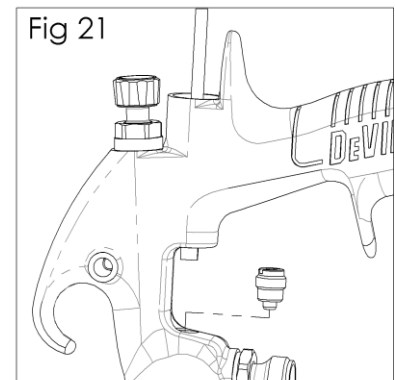
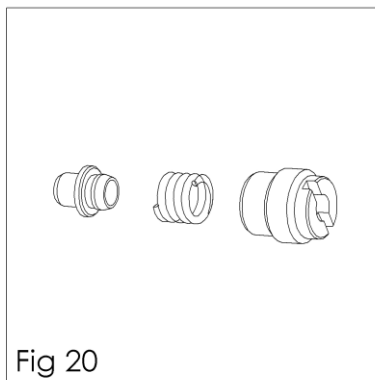
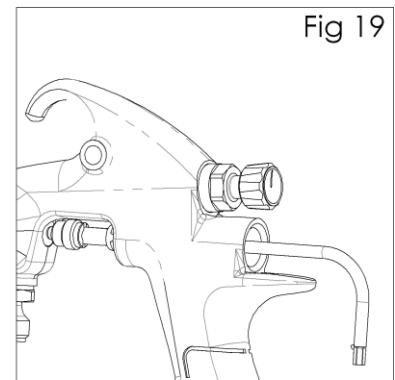
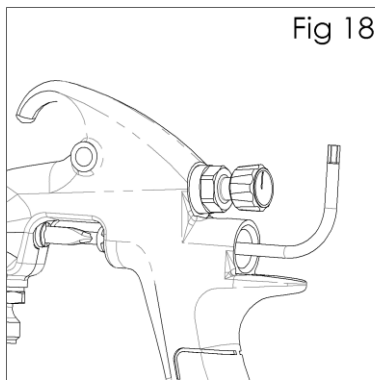

SPREADER VALVE ASSEMBLY

REPLACEMENT/MAINTENANCE

1. The spreader valve assembly can be replaced if damaged. Remove using 14 mm Spanner (59) (See figs 22 & 23). The internal seal can be replaced and is included in the Gun Rebuild Kit (See fig 24).

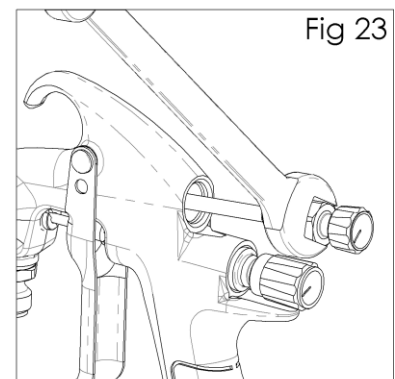
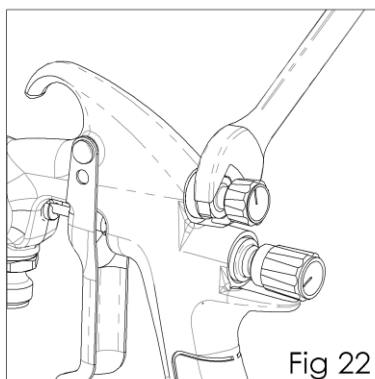

FLUID INLET SEAL

REPLACEMENT INSTRUCTIONS

1. Loosen Locknut (49) with 18mm Spanner (See fig 25).
2. Unscrew Fluid Inlet Adaptor (50) with 8mm Hex Key (See fig 26).
3. Remove Fluid Inlet Adaptor (See fig 27).
4. Remove seal (48) and replace with new seal (See fig 28).
5. Replace Fluid Inlet Adaptor (See fig 27)
6. Tighten with 8mm Hex Key to 26-28Nm (See Fig. 26).
7. Tighten Lock Nut (49) with 18mm Spanner (See Fig. 25).

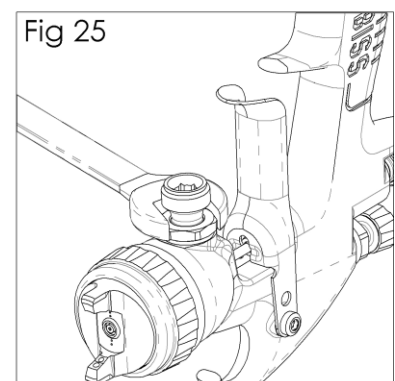
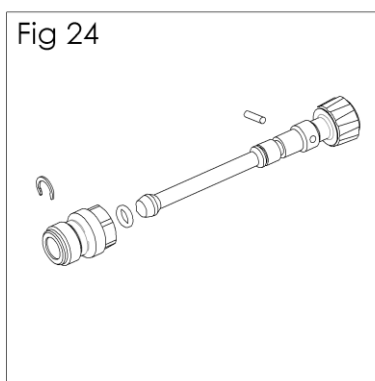

Parts Replacement/ Maintenance

SPRAY HEAD SEAL REPLACEMENT

1. Remove air cap and retaining ring (6). (See fig 29).
2. Remove fluid adjusting knob (28), spring (25), and spring pad (26). (See fig 4 p9).
3. Remove fluid needle (24) from gun body. (See fig 5 p9).
4. Remove fluid nozzle using 10mm Spanner (59). (See fig 30)
5. Remove spray head (9) and Seal (10) (See fig 31).
6. Remove seal (10) from spray head. (See fig 32).
7. Clean front of gun if required, using a soft brush, as well as the fluid nozzle, air cap, and retaining ring.
8. Place a new seal (10) into the front of the gun, making sure the flat of the seal is aligned to the flat in the gun. (See fig 33).
9. Fit the spray head (9), making sure the pin is engaged into the hole in the gun-body. (See fig 31).
10. Fit fluid nozzle (8) and air cap and retaining ring (6). Torque the fluid nozzle to 18–20 Nm (160–180 lbs.in). Do not over torque the fluid nozzle. (See figs 30, and 29)
11. Reassemble remaining parts in reverse order - fluid needle (24), Needle spring and pad (29), and fluid adjusting knob (28).
12. Trigger gun fully and screw in fluid adjusting knob (28) until it stops. Back it off 1/2 turn and gun will have full needle travel.
13. Trigger gun several times to verify correct operation.

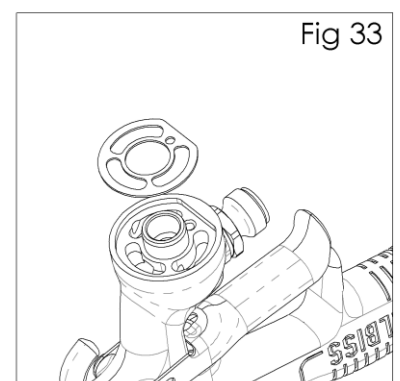
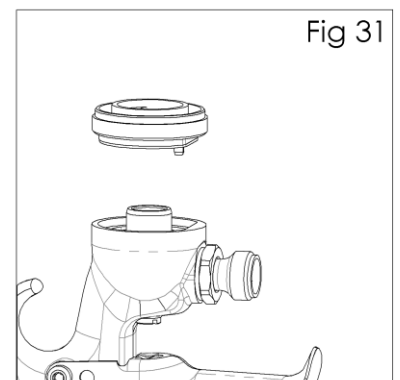
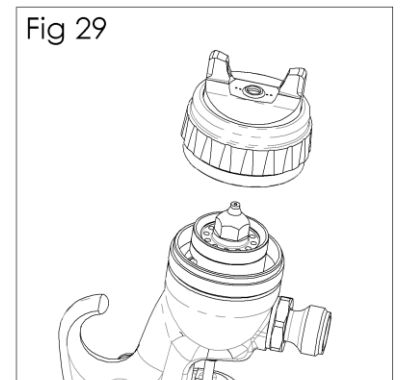
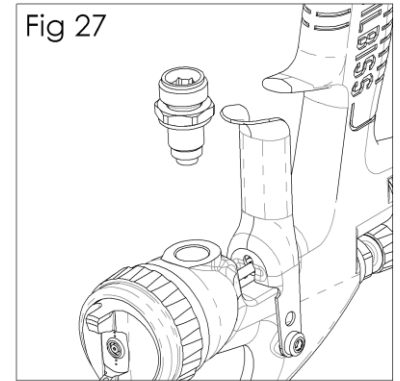
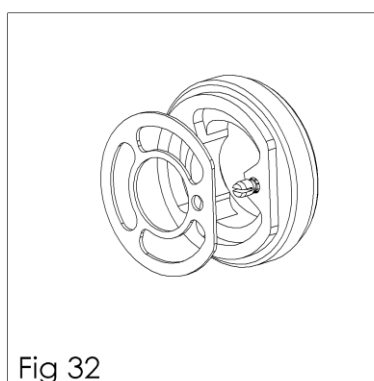
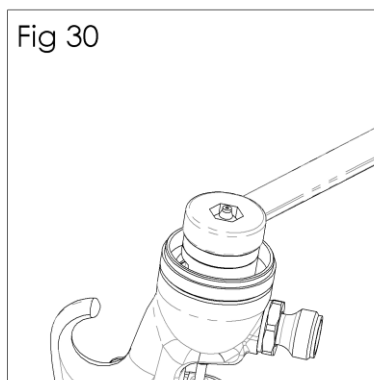
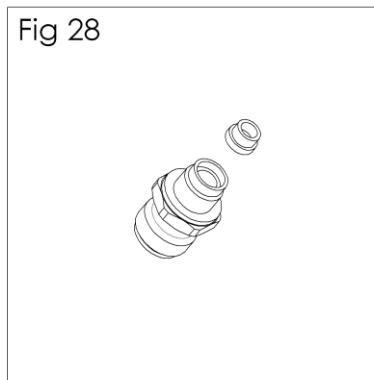
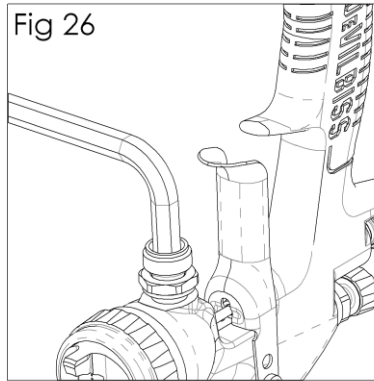

Fig 32

Fig 33

Parts Replacement/ Maintenance

SUCTION CUP LID

1. Remove drip free diaphragm (54). Clean or replace. Make sure the vent hole is kept clear. (see fig 34).
2. Remove cup lid gasket (53) (see fig 35).
3. Make Sure the vent hole in the lid (56) is clean and not blocked. (see fig 36).
4. It is recommended to replace the cup gasket (53) with a new one to avoid cup leaks (see fig 35).
5. Re-fit the drip free diaphragm. Position the vent hole in the diaphragm 180° away from the lid vent hole (see fig 34)

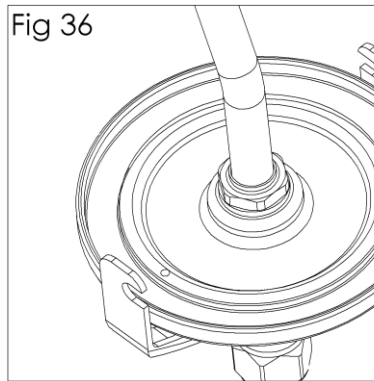
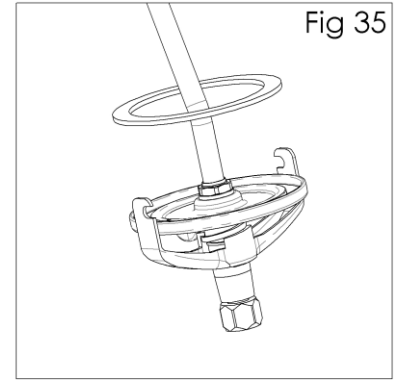
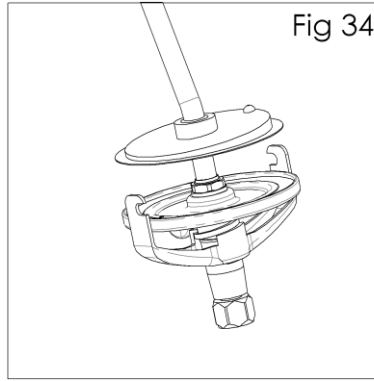

Chart 1 – Air Caps

PART No. FOR AIR CAP	TECHNOLOGY	MARKING ON AIR CAP	FLUID FEED	RECOMMENDED INLET PRESSURE (bar)	AIR FLOW (L/min) @ 2 bar
PRO-102-HV30-K	HVLP	HV30	Suction/Pressure	1.75	465
PRO-102-TE10-K	High Efficiency	TE10	Suction/Pressure	2.0	275
PRO-102-TE20-K	High Efficiency	TE20	Suction/Pressure	2.0	350
PRO-102-TE30-K	High Efficiency	TE30	Pressure Only	2.0	300
PRO-102-TE40-K	High Efficiency	TE40	Pressure Only	2.0	365

NOTE: When removing air cap from retaining ring, don't remove the Slip Ring (2) or Retaining Ring Seal (5) from the Retaining Ring. Damage to the parts may occur. Slip ring and Retaining Ring seal are not available as replacements. Simply wipe parts clean and reassemble with new or clean air cap.

Chart 2 – Fluid Nozzle Range & Fluid Needle

SPRAY GUN	PART No. ON FLUID NOZZLE	PART No. NEEDLE
PROPL (Pressure Feed)	PRO-205-085-K	PRO-320-085-10-K
	PRO-205-10-K	
	PRO-205-12-K	PRO-320-12-14-K
	PRO-205-14-K	
PROSL (Suction Feed)	PRO-200-16-K	PRO-325-K
	PRO-200-18-K	
	PRO-200-20-K	

NOTE: When replacing the fluid nozzle or fluid needle, replace both at the same time. Torque to 18–20 Nm (160–180 lbs.in). Do not over tighten the fluid nozzle. Use SN-28 (59) 10mm Spanner supplied with the gun and check with a torque wrench.



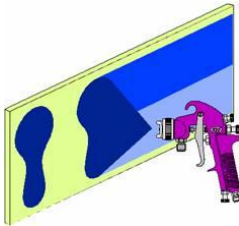
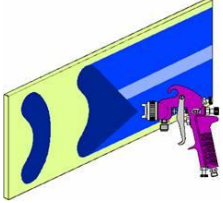
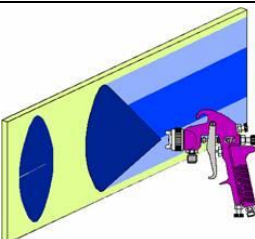
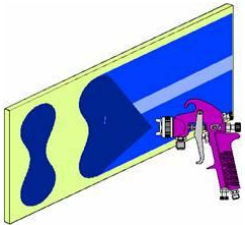
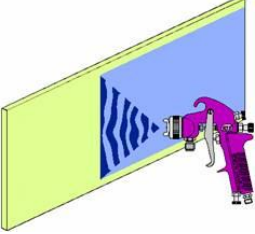





Troubleshooting Possible Problems in Operation

CONDITION	CAUSE	CORRECTION
<p>Heavy top or bottom pattern</p>  <p>Heavy right or left side pattern</p> 	<p>Horn holes plugged.</p> <p>Obstruction on top or bottom of fluid nozzle.</p> <p>Cap and/or nozzle seat dirty.</p> <p>Left or right side horn holes plugged.</p> <p>Dirt on left or right side of fluid nozzle.</p>	<p>Clean. Ream with non-metallic point.</p> <p>Clean.</p> <p>Clean.</p> <p>Clean. Ream with non-metallic point.</p> <p>Clean.</p>
<p>Remedies for the top-heavy, bottom-heavy, right-heavy, and left-heavy patterns:</p> <p>1. Determine if the obstruction is on the air cap or the fluid nozzle. Do this by making a test spray pattern. Then, rotate the cap one-half turn and spray another pattern. If the defect is inverted, obstruction is on the air cap. Clean the air cap as previously instructed. Also check for dried paint just inside the cap centre hole opening; remove by washing with solvent.</p> <p>2. If the defect is not inverted, it is on the fluid nozzle. Clean nozzle. If problem persists, renew nozzle.</p>		
<p>Heavy centre pattern</p> 	<p>Spreader adjustment valve set too low.</p> <p>Atomising pressure too low.</p> <p>Material too thick.</p>	<p>Turn out counter clockwise to achieve correct pattern.</p> <p>Increase pressure.</p> <p>Thin to correct consistency.</p>
<p>Split spray pattern</p> 	<p>Air pressure too high.</p> <p>Fluid adjusting knob turned in too far.</p> <p>Spreader adjusting valve set too high.</p>	<p>Reduce at regulator or gun handle.</p> <p>Turn out counter clockwise to achieve correct pattern.</p> <p>Turn in clockwise to achieve correct pattern.</p>
<p>Jerky or fluttering spray</p> 	<p>Loose or damaged fluid nozzle/seat</p> <p>Loose or broken cup fluid nipple</p> <p>Material level too low</p> <p>Container tipped too far</p> <p>Obstruction in fluid passage</p> <p>Loose fluid needle packing nut</p> <p>Damaged fluid needle packing</p>	<p>Tighten or replace</p> <p>Tighten or replace cup</p> <p>Refill</p> <p>Hold more upright</p> <p>Back flush with solvent</p> <p>Tighten</p> <p>Replace</p>
<p>Paint bubbles in cup</p>	<p>Fluid nozzle not tight.</p>	<p>Tighten to 18–20 Nm (160–180 lbs.in).</p>
<p>Fluid leaking or dripping from cup lid</p>	<p>Cup lid loose.</p> <p>Dirty cup or lid.</p> <p>Cracked cup or lid.</p>	<p>Push in or replace.</p> <p>Clean.</p> <p>Replace cup and lid.</p>

Troubleshooting Possible Problems in Operation (cont.)

Starved spray pattern	Inadequate material flow Blocked vent in Cup lid Low atomisation air pressure	Wind fluid adjusting knob out or change to larger fluid nozzle size Clean lid and unblock vent Increase air pressure and rebalance gun.
Excessive overspray	Air pressure too high. Gun too far from work surface.	Reduce air pressure. Adjust to correct distance.
Dry spray	Air pressure too high. Gun too far from work surface. Gun motion too fast. Fluid flow too low.	Reduce air pressure. Adjust to correct distance. Slow down. Wind out needle adjusting screw or use larger nozzle size.
Fluid leaking from packing nut	Packing worn.	Replace.
Fluid leaking or dripping from front of gun	Fluid nozzle or fluid needle worn or damaged. Foreign matter in fluid nozzle. Fluid needle dirty or stuck in needle packing Wrong size fluid needle or fluid nozzle.	Replace fluid nozzle and fluid needle. Clean. Clean Replace fluid nozzle and fluid needle.
Fluid dripping or leaking from bottom of cup	Cup loose on gun. Cup fluid inlet seat dirty.	Tighten Clean.
Runs and sags	Too much material flow. Material too thin. Gun tilted on an angle, or gun motion too slow.	Turn fluid adjusting knob clockwise or switch to smaller fluid nozzle and fluid needle size. Mix correctly or apply light coats. Hold gun at right angle to work and adapt to correct gun technique.

ACCESSORIES

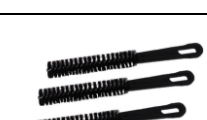
DGi Digital Pressure Gauge	DGIPRO-502-BAR		Gun Stand	GFV-50-F	
Spanner	SN-406		MC-1-K50	600 cc Mixing Cups pack of 50	
Torx driver			10m x 8mm bore rubber air hose with ¼ fittings	H-6065-B (BSP) H-6065-N (NPS)	
Cleaning Brush			Pack of four QD fittings	MPV-463	
Cleaning Brush		4900-5-1-K3		MPV Swivel	MPV-60-K3

WARRANTY

This product is covered by ITW Finishing Systems and Products Limited one year warranty.

ITW Finishing Systems and Products
 Ringwood Road,
 Bournemouth,
 BH11 9LH, UK
 Tel. No. (01202) 571111
 Telefax No. (01202) 581940,
 Website address <http://www.itwifeuro.com>

ITW Finishing Systems and Products is a Division of ITW Ltd. Reg. Office: Admiral House, St Leonard's Road, Windsor, Berkshire, SL4 3BL, UK. Registered in England: No 559693 Vat No 619 5461 24