



## CONVENTIONAL SUCTION FEED SPRAY GUN

- Renowned DeVilbiss atomisation quality and paint distribution
- Standard setting fit, feel and balance.
- Choice of the 30+ or 186+ high performance air caps
- Durable forged and polished aluminium gun body
- Precision control of airflow, fluid flow and pattern shape
- Stainless steel fluid tip and needle

Part Number Explanation

**JGA - S - 186 - 14**  
 Model                      Suction                      Air Cap                      Fluid Tip

### Specification

Air Inlet Pressure	3.4 Bar (50psi)
Air Consumption (30+ Air Cap)	275 l/min (9.7cfm)
Air Consumption (186+ Air Cap)	331 l/min (11.7 cfm)
Air Inlet Thread	1/4" Universal (m)
Cup Capacity	1 litre
Weight complete with cup	1168gm
Air Cap & Ring	Plated Brass
Fluid Tip	Stainless Steel
Fluid Needle	Stainless Steel



### JGA Spray Gun Kits

Part No	Description
JGA-S30-18	Suction feed refinishers kit with 30+ air cap & 1.8mm fluid tip
JGA-S186-14	Suction feed refinishers kit with 186+ air cap & 1.4mm fluid tip
JGA-S186-16	Suction feed refinishers kit with 186+ air cap & 1.6mm fluid tip

Kit includes JGA Suction gun, cup, paint filter and multi fit spanner

### Accessories

Part No	Description
AV-4239-***	Air Cap and Retaining Ring (186+ / 30+)
KK-4504-***-**	Air Cap, Tip & Needle Kit
KK-4502-**-H	GTi service kit – Includes fluid tip and needle
KK-4585	Gun maintenance kit – seals, springs, packing etc
DGi-501-BAR	Digital pressure gauge – reads in bars
HAF-507-K12	Lightweight, in-line air filter
KR-483-K10	Kit of 10 mesh KR cup strainers (115 micron)
KR-484-K10	Kit of 10 mesh KR cup strainers (350 micron)
4900-5-1-K3	Pack of three cleaning brushes
MPV-60-K3	Male quick detach Uni swivel stem to fit onto gun air inlet
KR-566-1-B	1 litre standard suction cup for JGA
KR-69-K3	Kit of 3 Leather gaskets
KR-11-K3	Kit of 3 Tri-Seal gaskets

\*\*\* = Air cap. \*\* = Fluid tip size.

### No 30+ Air Cap



DGi-501-BAR



KK-4502



KR-484-K10



7000-114-K2



KR-11-K3

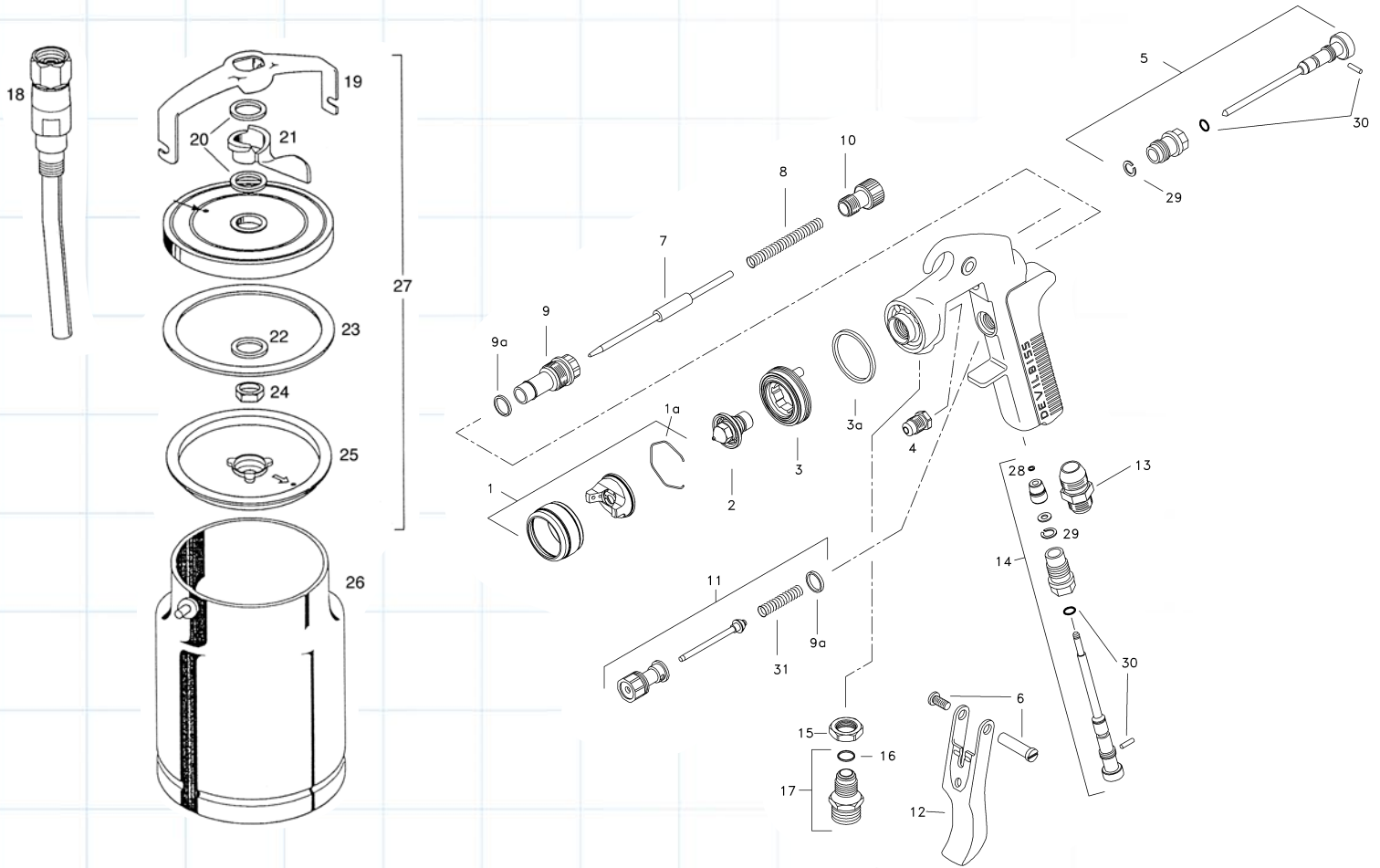

Ref. No	Description	Part No.	Qty
1	Air Cap/Retaining ring (* = 186+ or 30+)	AV-4239-***	1
1a	Spring Clip - Kit of 5	JGA-156-K5	1
2	Nozzle (* = EX-1.8mm, FF-1.4mm, FW-1.6mm)	AV-645-*	1
3	Baffle & Seal	JGD-402-K	1
3a	Baffle seal - Kit of 5	GTI-33-K5	1
4	Packing	GTI-439-K2	1
5	Spreader Valve	GTI-405-K	1
6	Stud and Screw	GTI-408-K5	1
7	Needle (* = DEX or FF)	JGA-421*-K	1
8	Spring - Kit of 5	GTI-409-K5	1
9	Bushing	JGA-17	1
9a	Seal - Kit of 5	JGS-72-K5	1
10	Needle Adjusting Screw	GTI-414-K	1
11	Valve Assembly	JGK-449	1
12	Trigger	GTI-108	1
13	Connector	JGA-158	1
14	Airflow Valve	GTI-415-K	1
15	Lock Nut - Kit of 5	JGA-51-K5	1
<b>Ref. No</b>	<b>Description</b>	<b>Part No.</b>	<b>Qty</b>

16	Seal	23165-001	1
17	Fluid Inlet Connector and seal	JGA-159-K	1
18	Fluid Tube	KR-456-B	1
19	Yoke	KR-77-1	1
20	Washer - kit of 5	KS-48-K5	2
21	Cam and Washer Kit	KR-445-1	1
22	Washer - Kit of 5	KR-40-K5	1
23	Lid Gasket - kit of 3	KR-11-K3	1
24	Nut - kit of 5	KR-94-K5	1
25	Drip free diaphragm—kit of 5	KR-115-K5	1
26	Cup	KR-466-K	1
27	Cup lid assembly	KR-4001-B	1
28	Circlip - Kit of 5	25746-007-K5	1
29	Circlip - Kit of 5	SST-8434-K5	2
30	Seal + Pin Kit ( + SST-8434-K5)	GTI-428-K5	2
31	Spring	JGV-262-K5	1



## CONVENTIONAL PRESSURE FEED SPRAY GUN

Renowned DeVilbiss atomisation quality and paint distribution

Standard setting fit, feel and balance.

Choice of the 30+, 186+ or 765 high performance air caps

Durable forged and polished aluminium gun body

Precision control of airflow, fluid flow and pattern shape

Stainless steel fluid tip and needle

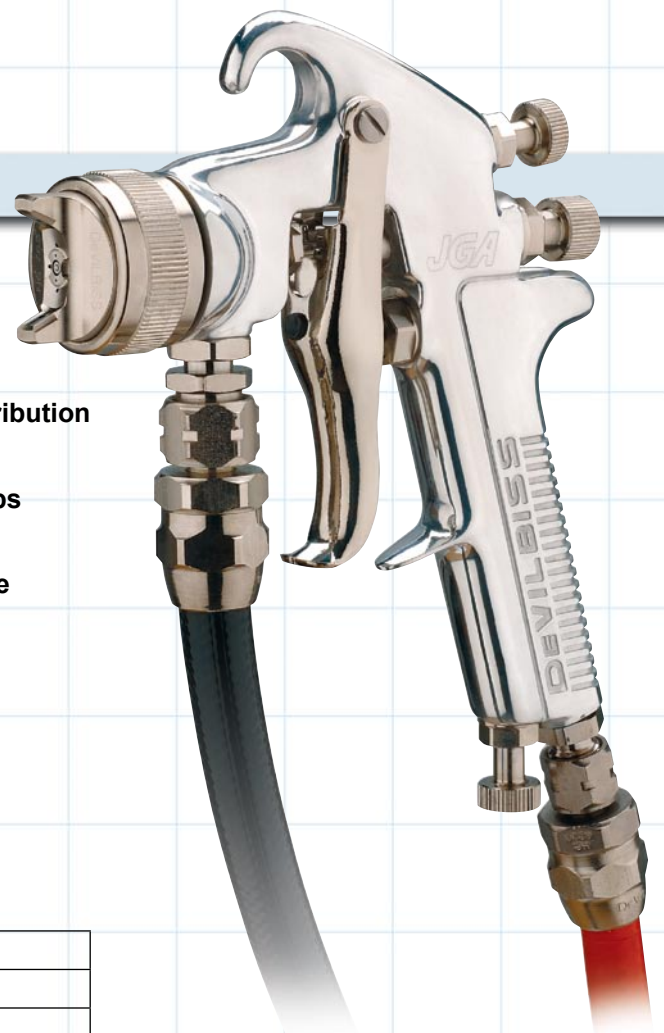

Part Number Explanation

**JGA - 558-FWH - 765**

Model:Suction

Fluid Tip

Air Cap

### Specification

Air Inlet Pressure	3.4 Bar (50psi)
Air Consumption (30+ Air Cap)	275 l/min (9.7cfm)
Air Consumption (186+ Air Cap)	331 l/min (11.7 cfm)
Air Consumption (765 Air Cap)	547 l/min (19.3 cfm)
Air Inlet Thread	1/4" Universal (m)
Weight complete with cup	1168gm
Air Cap & Ring	Plated Brass
Fluid Tip	Stainless Steel
Fluid Needle	Stainless Steel



No 765 Air Cap

### JGA Spray Gun Kits

Part No	Description
JGA-558FFH-30B	Pressure feed refinishers kit with 30+ air cap & 1.4mm fluid tip
JGA-558FWH-186B	Pressure feed refinishers kit with 186+ air cap & 1.6mm fluid tip
JGA-558FFH-765B	Pressure feed refinishers kit with 765 air cap & 1.4mm fluid tip



DGI-501-BAR



KK-4585

### Accessories

Part No	Description
AV-4239-***	Air Cap and Retaining Ring (186+ / 30+ / 765)
KK-4504-***-**	Air Cap, Tip & Needle Kit
KK-4502-**-H	GTi service kit – Includes fluid tip and needle
KK-4585	Gun maintenance kit – seals, springs, packing etc
DGI-501-BAR	Digital pressure gauge – reads in bars
HAF-507-K12	Lightweight, in-line air filter
4900-5-1-K3	Pack of three cleaning brushes
MPV-60-K3	Male quick detach Uni swivel stem to fit onto gun air inlet



HAF-507-K12

\*\*\* = Air cap. \*\* = Fluid tip size.



## CONVENTIONAL TECHNOLOGY

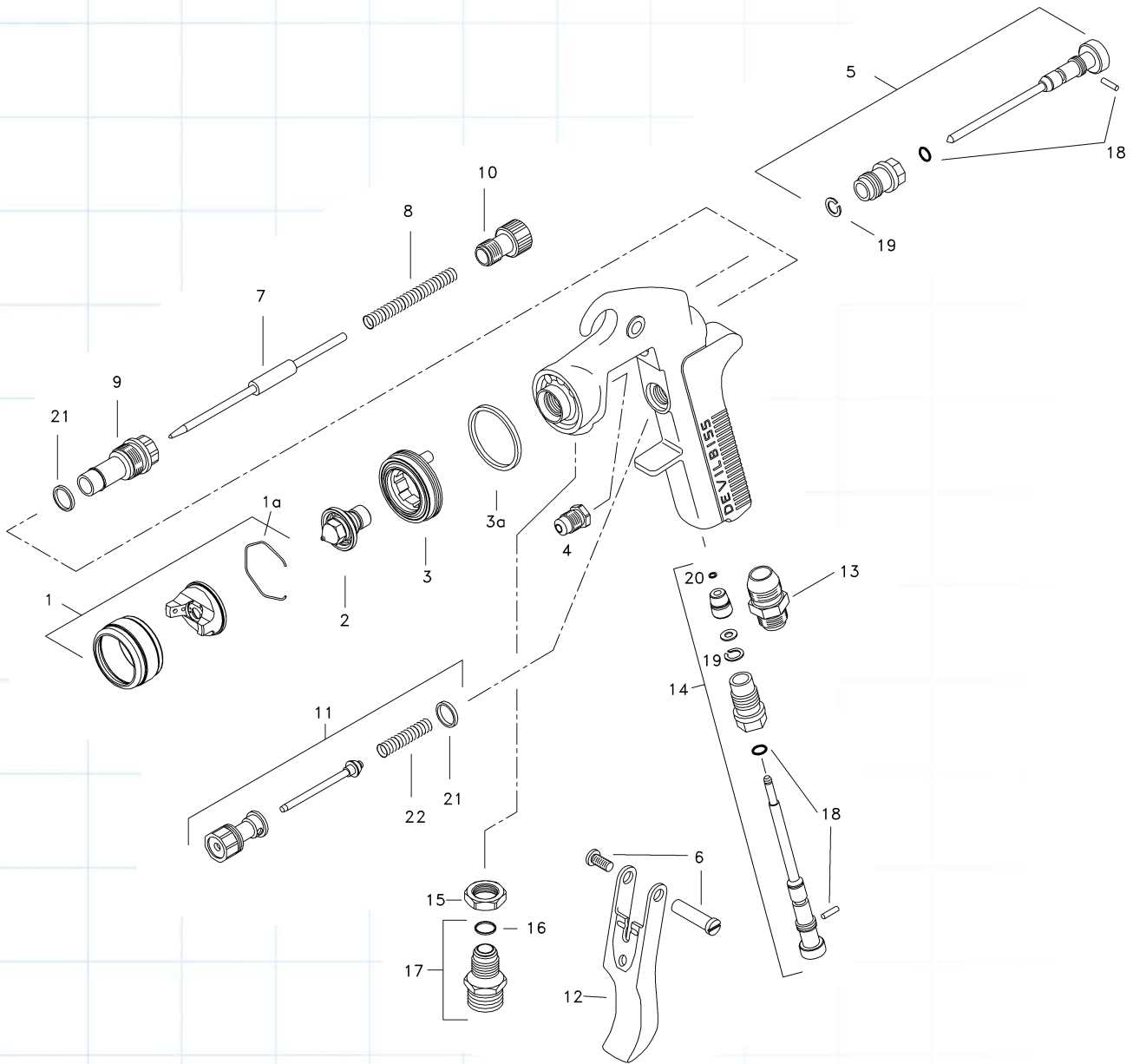

Ref. No	Description	Part No.	Qty
1	Air Cap/Retaining ring ( * = 186+ / 30+ / 765)	AV-4239-*	1
1a	Spring Clip - Kit of 5	JGA-156-K5	1
2	Nozzle ( * = EX-1.8mm, FF-1.4mm, FW-1.6mm)	AV-645-*	1
3	Baffle & Seal	JGD-402-K	1
3a	Baffle seal - Kit of 5	GTI-33-K5	1
4	Packing	GTI-439-K2	1
5	Spreader Valve	GTI-405-K	1
6	Stud and Screw	GTI-408-K5	1
7	Needle ( * = DEX / FF)	JGA-421-*-K	1
8	Spring - Kit of 5	GTI-409-K5	1
9	Bushing	JGA-17	1
10	Needle Adjusting Screw	GTI-414-K	1
Ref. No	Description	Part No.	Qty

11	Valve Assembly	JGK-449	1
12	Trigger	GTI-108	1
13	Connector	JGA-158	1
14	Airflow Valve	GTI-415-K	1
15	Lock Nut - Kit of 5	JGA-51-K5	1
16	Seal	23165-001	1
17	Fluid Inlet Connector and seal	JGA-159-K	1
18	Seal + Pin Kit ( + SST-8434-K5)	GTI-428-K5	2
19	Circlip - Kit of 5	SST-8434-K5	2
20	Circlip - Kit of 5	25746-007-K5	1
21	Seal - Kit of 5	JGS-72-K5	2
22	Spring	JGV-262-K5	1